

Vibration Tumbler Screening Machines VTS

Wide range of applications in dry and wet screening



Vibration Tumbler Screening Machines VTS for unlimited applications.

Screening machines of the VTS series are suitable for the economical processing of almost all bulk solids with fine to medium and coarse grains.

The VTS is also ideal for screening of wet materials. The vibrating motion can be adjusted to match the required screening quality and the throughput.

Versatile use

- Dry and wet screening
- Classification up to 4 fractions
- Protective and control screening
- Removal of dust
- Removal of liquids

Features

- Flexible adaptation to the product
- Modular system
- Bouncing-ball or ultrasonic screen cleaning
- Durable screen mesh
- Simple and quick screen replacement
- Dust- and water-tight
- Low power consumption
- Low foundation loading

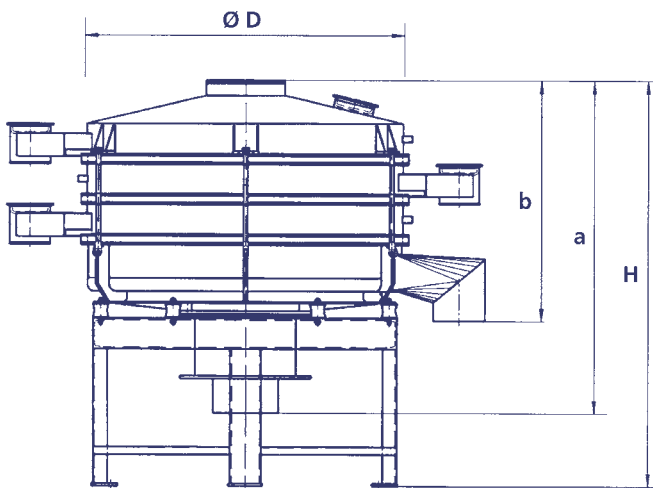

Types	VTS 600	VTS 800	VTS 950	VTS 1200	VTS 1400
Ø D mm	600	800	1000	1200	1427
Screen area per deck m ²	0.28	0.5	0.7	1.1	1.59
Rated electrical power kW	0.3	0.55	1.1	1.6	2.2
Weight kg	(without supporting frame)				
1-Deck	140	200	280	340	555
2-Decks	152	220	320	380	625
3-Decks	160	240	360	420	695
Dimensions mm	H / a / b	H / a / b	H / a / b	H / a / b	H / a / b
1-Deck	938 / 730 / 380	1068 / 772 / 428	1065 / 787 / 373	1268 / 985 / 628	1330 / 999 / 485
2-Decks	1016 / 808 / 458	1205 / 909 / 565	1180 / 902 / 488	1425 / 1142 / 785	1469 / 1138 / 624
3-Decks	1094 / 886 / 536	1342 / 1046 / 702	1295 / 1017 / 603	1580 / 1299 / 940	1608 / 1277 / 763

Options

- With cover or open top
- With hinged cover
- With quick-action clamps
- One to three decks
- High-quality finish for the pharmaceutical and foodstuff industries
- With bouncing-ball cleaning
- With spraying device
- ATEX certified



VTS screening machine with ultrasonic cleaning

Alternatively to the bouncing-ball cleaning system, ultrasonic cleaning system ensures continuous efficient debinding of the mesh cloth, thus resulting in a durable and continuous screening.



Heated system for screening of liquid chocolate

Heated VTS systems are used for the control screening of liquid chocolate and cocoa. The heating system keeps the product at a constant temperature in order to prevent it from solidifying.



Allgaier Process Technology GmbH

Ulmer Straße 75
73066 Uhingen
Germany
Phone: +49 7161 301-175
Fax: +49 7161 34268
process-technology@allgaier.de
www.allgaier.de

Manufacturing companies:

Mogensen GmbH & Co. KG

Kronskamp 126
22880 Wedel
Germany
Phone: +49 4103 8042-0
Fax: +49 4103 8042-40
info@mogensen.de
www.mogensen.de

Fredrik Mogensen AB

Sveavägen 26
544 21 Hjo
Sweden
Phone: +46 503 3234-0
Fax: +46 503 13878
info@mogensen.se
www.mogensen.se

Allgaier Mogensen S.A.U.

C/ Téllez, 24 - Oficina 4A
28007 Madrid
Spain
Phone: +34 91 5776277
Fax: +34 91 5757495
info@almo.es
www.almo.es