

Drying Technologies for Mineral Raw Materials

Rotary drums and fluidized bed dryers add quality to your process

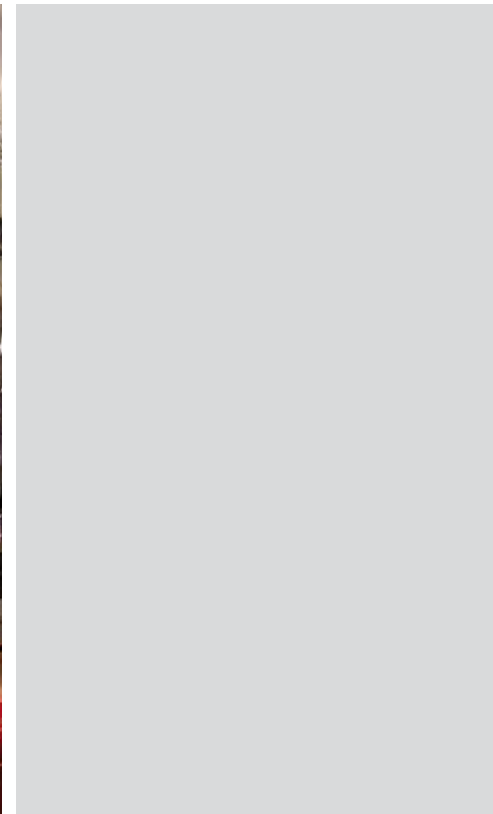

Drying Technologies for Mineral Raw Materials

Rotary drums and fluidized bed dryers add quality to your process

Allgaier drum and fluidized bed dryers make processes more productive

Today, Allgaier dryers are used successfully in almost all industrial sectors. Particularly in the mineral processing industry but also in the chemical and fertilizer industry and in recycling operations, the rotary drum dryers and fluidized bed dryers prove their extraordinary abilities.

Allgaier drying systems are extremely adaptable. Their design features and the large number of available options permit the design of productive processes.

Application areas of fluidized bed and drum dryers

- Agro Chemicals
 - Fertilizers
 - Recycling
 - Waste materials
 - Inorganic sludges
 - Filter cakes
 - Iron sulphate
 - Titanium dioxide
 - Hydroxides
 - Limestone
 - Magnesite
 - Magnetite
 - Metal chips
 - Wood chips
 - Gypsum
 - Ore
 - Ilmenite
 - Slag
 - Potash
 - Salts
 - Dolomite
 - Fly ash
 - Coke
 - Anthracite
 - Talc
 - Steel shot
 - Bone grist
 - Fodder
 - Cocoa nibs
 - Rice
- Building materials
 - Sand
 - Minerals
 - Limestone aggregates
 - Glass cullet
 - Moulding sand
 - Ceramics
 - Chemical substances
 - Pigments
 - Clay
 - Bentonite

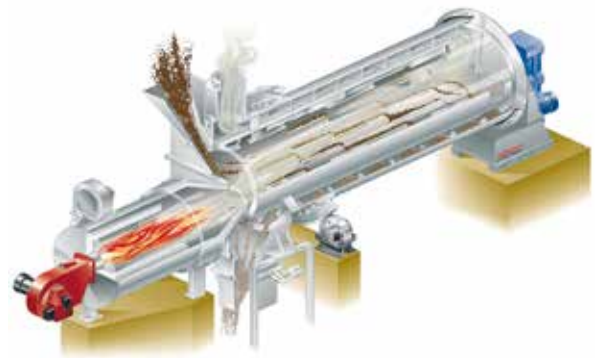

Features

- High thermal efficiency
- Few parts subject to wear
- Product-optimized drying
- Large number of process options
- Easy access and thus easier replacement of spare parts
- Variable design for different products



For every requirement

Regardless of whether a single unit or a complete system is needed – Allgaier can meet every requirement. With complete solutions, including engineering, installation and commissioning, Allgaier proves their competence in the area of plant construction.



Drum dryers, System MOZER® Single-shell, double-shell and triple-shell drums

Allgaier rotary drum dryers are used, particularly in the minerals industry, for drying free flowing but also sticky and abrasive wet materials.

Their main features are high throughput rates and the ability to process solid materials with widely differing granulometric properties.

The drum dryers are available in single-shell, double-shell and triple-shell versions.

The design ensures high performance in a small space. Special versions also permit the use of combined processes.

Allgaier outside – MOZER® inside

The users of drum dryers do not need to give up the proven MOZER technology.

Allgaier still produces and develops the drum dryers system „Mozer“ with their unbeaten quality and performance.

Single-shell drum TTD

For coarse-grained materials, clay products, broken glass, etc.

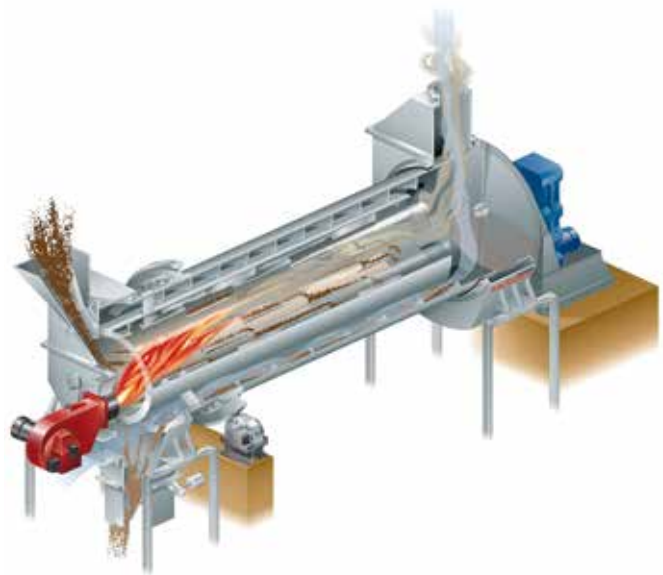
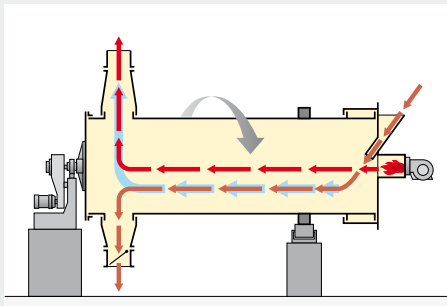

Double-shell drum TT

For drying of fine-grained minerals, silica sand and ore.

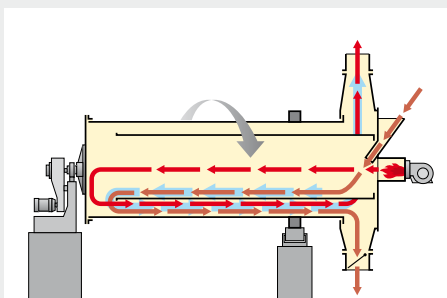

Triple-shell drum TT-T

For drying materials which require long dwell times. For easily free-flowing products with fine to medium grain sizes.

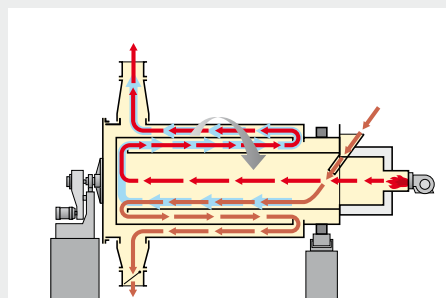

Combined processes

Allgaier has extended and perfected the use of drum dryers. The result of this work is a range of designs for new combined processes in a single system which are therefore very effective and economical.

A technical highlight is the double-shell drum dryer system TK and it's even more efficient sytem TK+, which dries and cools the sand in a single step. The TK+ system is feeding part of the wet product, referred to as the "bypassing product", directly into the outer drum. There it is mixed with the dry and warm product from the inner drum which dries the wet bypassing product and cools down the dry product by evaporative cooling.

Reduced energy consumption by up to 20 %!

Drying/cooling

System TK

Double-shell drum with air-cooling path, for grain sizes up to 32 mm (sand, crushed limestone, etc.)

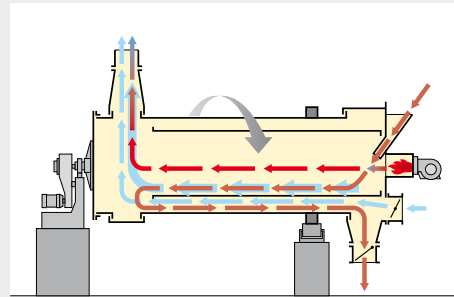

Drying/cooling of sand

System TK+

Double-shell drum for combined drying and evaporative cooling of sand. Well proven in the manufacturing of ready mixed dry products like mortar and plaster.

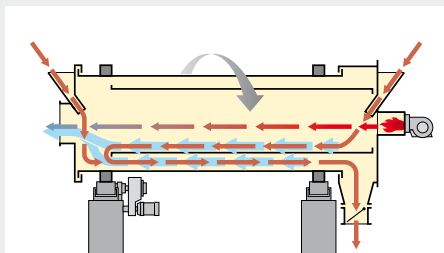

Drying/crushing

System TTM

With grinder. Dries and crushes lumpy materials such as filter cakes. This improves or enables the drying of lumpy products to produce fine grained dry materials.

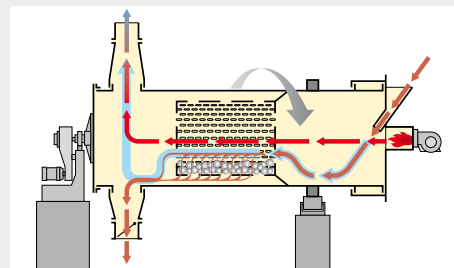

Drying/screening

System TTT

With screening unit. This system dries and screens many types of materials with reasonably good separation (aluminium scrap, shredded recycling products, ...). There is thus a reduced need for separate downstream screening steps.

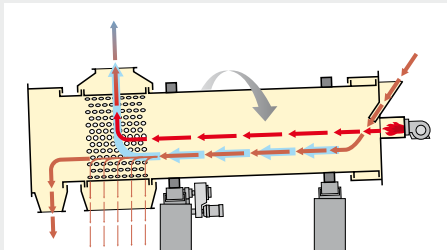

Drying/cleaning

System TRH

With cleaning zone. This system replaces separate washing steps especially for lime stone aggregates or increases the amount of good material from dry separation.

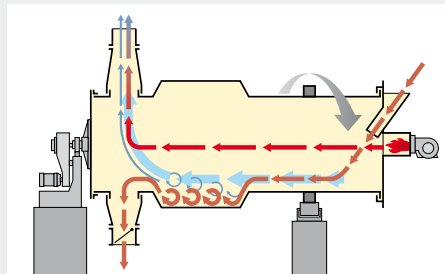

Granulation and coating

System ST

This system produces granules from powders and cakes, such as of fertilizers, lime, bentonite and clay. It can also be used for coating applications (urea, potash granules).

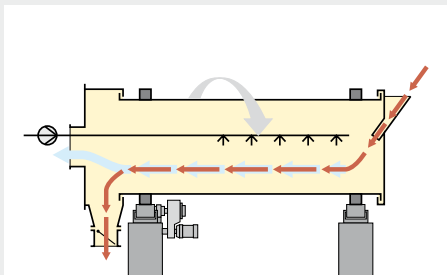

Drying of waste

System TTD

Municipal waste or paper rejects can be dried quickly and economically in drum dryers.

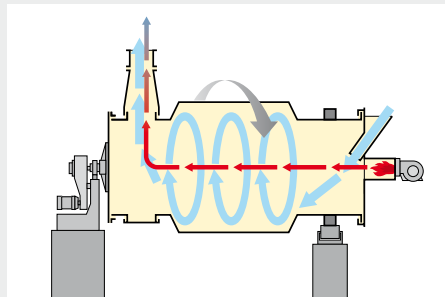

Cooling

System RK/KT-R

Two different systems of indirect rotary drum coolers for hot and very hot bulk materials (titanium dioxide, slag, hydroxides, gypsum) with heat recovery from the hot products.

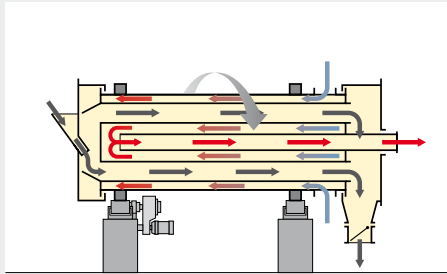

Cooling

System SK

Drum dryers can be combined with static water-cooled sand coolers to achieve uniformly low outlet temperatures, regardless of the ambient temperature.

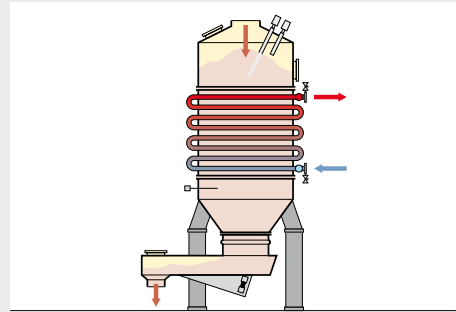

Fluidized bed dryers and coolers

Allgaier fluidized bed dryers can be used advantageously for the treatment of many material substances, such as sand, limestone and ceramics and also for pellets and granules, mineral fertilizers, salt and fine chemicals.

The high rate of heat transfer in the fluidized bed ensures economical solutions and results in small plants.

The dryers are extremely robust and have no moving parts inside the process space. This results in minimal costs for maintenance and spare parts.



Features

- Low temperatures of the dried materials
- Careful drying of sensitive products like granules and pellets
- Exhaust-air heat recovery systems available
- Simultaneous dust removal from the fluid bed
- The product residence time and the quality can be adjusted by regulating the height of the fluidized bed

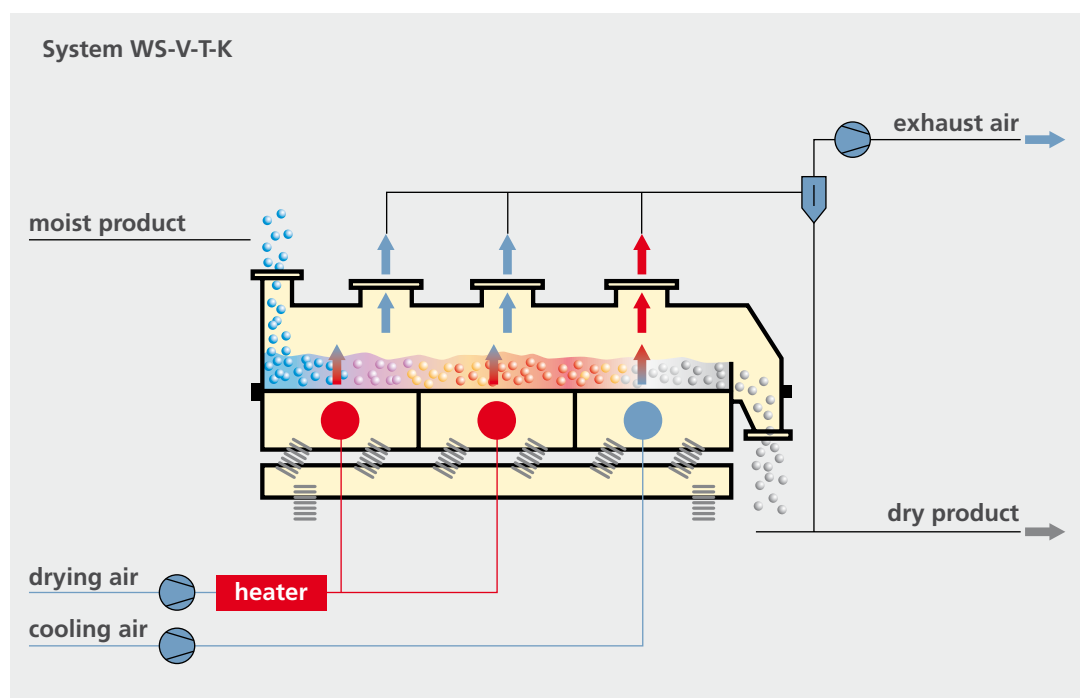



Application areas

	Drum dryers	Fluidized bed dryers
Materials to be dried	Pourable to sludgy materials with large grains or lumps and major variations in the grain size and moisture content	Dusts, powders, granules, crystals, pellets, large-grained goods, goods which cake easily, thermally sensitive materials, mechanically sensitive materials, ...
Application areas	Mineral substances, sand, sludge, limestone, gypsum, fertilizers, hydroxides, animal fodder, coal, waste materials, wood, domestic garbage, ...	Fine material substances, sand, clay, fertilizers, foodstuffs, chemicals, plastics, recycled materials, salts, pigments
Processes	Drying, cooling, mixing Pyrolysis, calcination Coating, granulation	Drying, cooling Granulation, agglomeration Crystallization, roasting, calcination
Combined processes	Drying / cooling (sand, limestone, broken rock, clay, ...) Drying / cleaning (dirty natural stone) Drying / screening (shredded materials) Drying/crushing (filter cakes) Drying of granulates (sludges, cakes)	Drying / cooling Granulating / drying / cooling Drying / grading / cooling Drying / dust removal / filler removal
Models and versions	Single-shell, double-shell and triple-shell drums Separate combustion chamber available	Static fluidized bed dryers / coolers without mechanical drives Vibrating fluidized bed dryers / coolers Fluid bed spray granulators Suspension and past dryers Batch dryers
Heat-transfer media	Direct heating with flue gases produced by the combustion of natural gas, mineral oil or coal. Indirect heating with saturated steam, thermo-oil, etc.	Direct heating with flue gases produced by the combustion of natural gas, mineral oil or coal. Indirect heating with saturated steam, thermo-oil, etc.



Service and Test Center

Reliable after-sales service

Allgaier is a reliable partner from the start of a project to the after-sales service – with very competent consultant engineers, a high level of mobility and a dependable spare part service.

Process knowledge for better processes

Since the drying behaviour of moist products varies widely, the drying systems must be designed and adapted accordingly – a task which requires

a lot of expertise, experience and instinct and is not easy.

The Allgaier Test Center is attuned to this and finds the best solution with the aid of practical tests.

With the support of experienced specialists, the test center carries out product-development work for customers. It goes without saying that this work is kept absolutely confidential, in our client's interest.



ALLGAIER

Allgaier-Group

Competent spare parts and customer service

Spare parts hotline: +49 7161 301-293
service-tro@allgaier.de

- Spare and wearing parts in original quality
- Modernization, retrofit, repair and service of existing drying systems
- Process consulting
- Energy consulting
- Product development



ALLGAIER

PROCESS TECHNOLOGY

ALLGAIER Process Technology GmbH

Ulmer Strasse 75
73066 Uhingen
Germany
Phone: +49 7161 301-100
Fax: +49 7161 301-5035
process-technology@allgaier.de
www.allgaier.de

