

## Recycling of prescreened stone



**drying & cleaning**

*Modern bulk material technology intelligently combined*

## Drying & cleaning: Efficient and economical.

**System TRH**

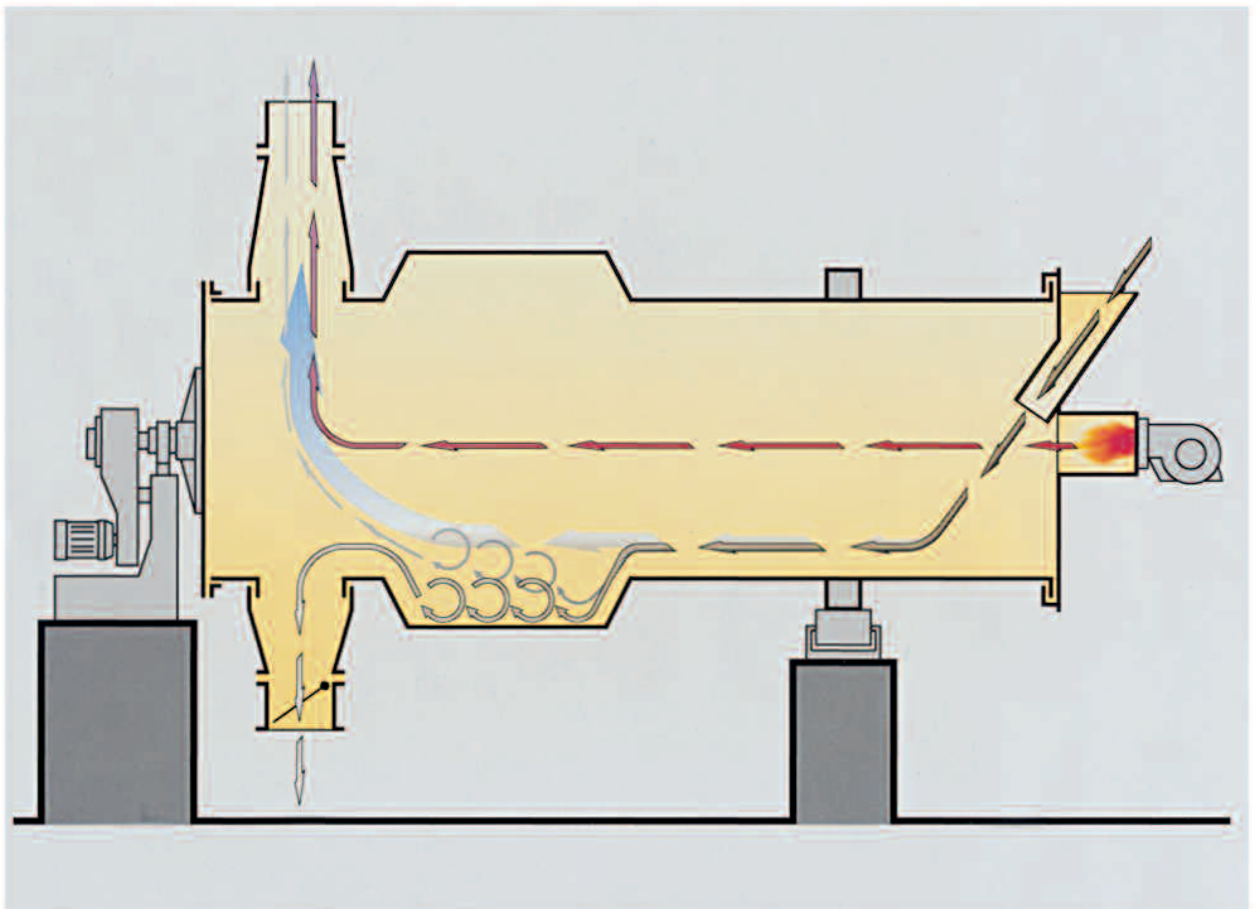

Wet and dirty material is fed into the drum and is dried in the first treatment zone. In the second treatment zone, the cleaning zone, adherent mud and dirt is rubbed off the stone and the resultant dust is blown out with the exhaust air. The cleaned stone leaves the drum by way of the outer casing. The dust, which is filtered from the exhaust air in a dust extraction unit can be further utilised.

- Adherent clay and loam is removed completely from the stone
- A single unit serves for both drying and cleaning
- Conventional washing of the material is unnecessary

- The cleaning zone can be readily adapted to the dirtiness of the material concerned
- Further utilisation of the mineral components is possible
- The expense of dumping uncleaned material is avoided

**Patent pending**

# Recovery of natural stone from prescreened rubble

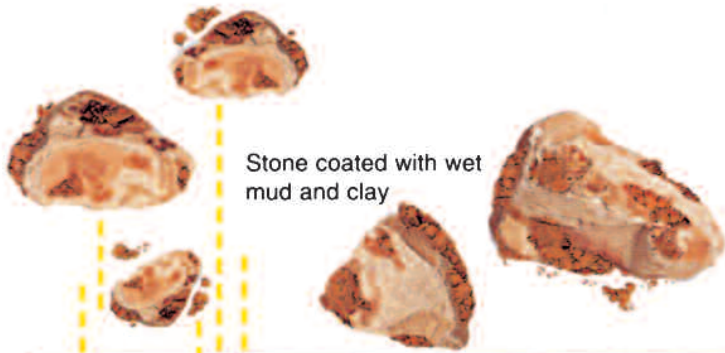

Stone coated with wet mud and clay



exhaust air

mineral components for further processing

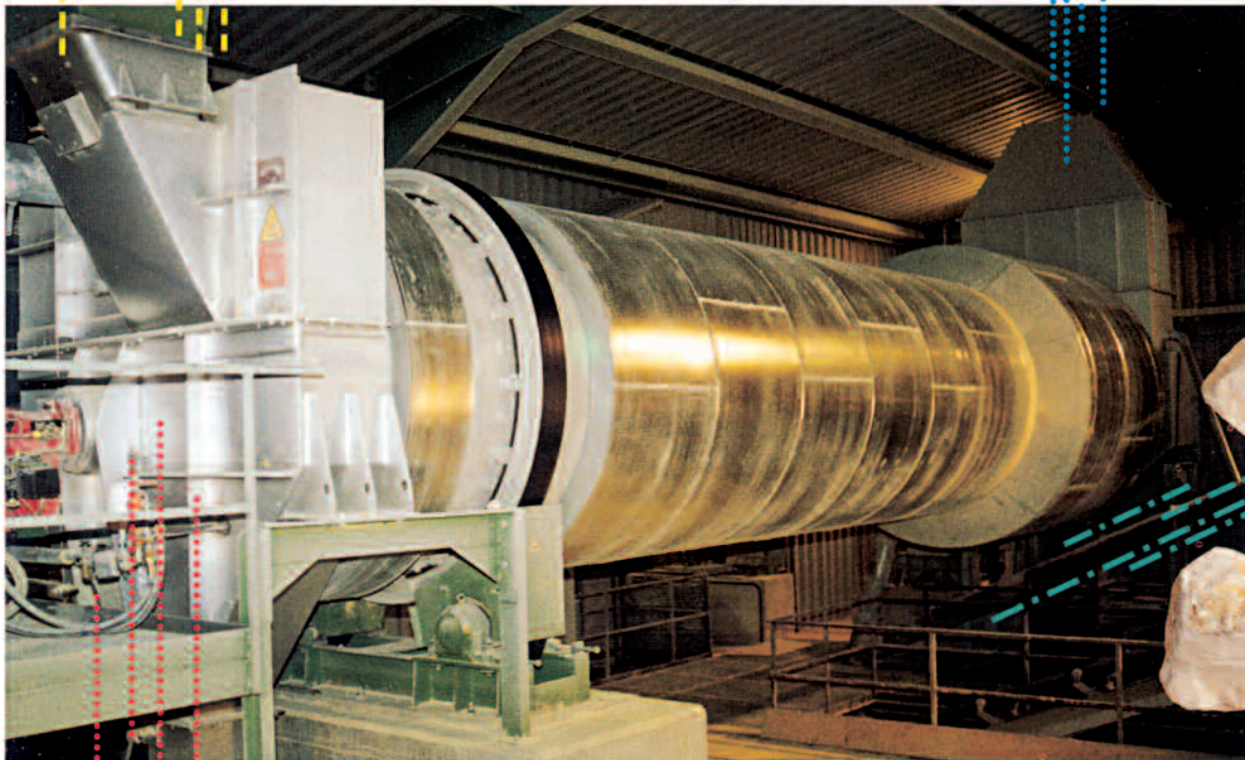

natural stone for further use

Heat for the combined drying & cleaning drum can be provided by means of a burner using natural gas, diesel oil or some other fuel either:



directly flange mounted on the drum



with an intermediate hot gas generator (for sensitive materials)

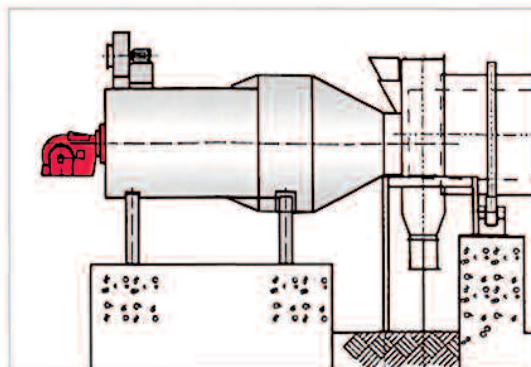

The TRH system can be operated with great economy if waste heat is available in the form of exhaust air from a block-type thermal power station or furnace lines. Such warm air is fed to the dryer after being brought to the required temperature in the hot gas generator with a considerable saving in fuel.

**Allgaier Process Technology GmbH**

Ulmer Straße 75  
73066 Uhingen  
Germany  
Phone: +49 7161 301-175  
Fax: +49 7161 34268  
process-technology@allgaier.de  
www.allgaier.de

Adolf-Safft-Straße 10  
73037 Göppingen  
Germany  
Phone: +49 7161 301-100  
Fax: +49 7161 301-5035  
trockner@allgaier.de  
www.allgaier.de

**Manufacturing companies:**

---

**Mogensen GmbH & Co. KG**

Kronskamp 126  
22880 Wedel  
Germany  
Phone: +49 4103 8042-0  
Fax: +49 4103 8042-40  
info@mogensen.de  
www.mogensen.de

**Fredrik Mogensen AB**

Sveavägen 26  
544 21 Hjo  
Sweden  
Phone: +46 503 3234-0  
Fax: +46 503 13878  
info@mogensen.se  
www.mogensen.se

**Allgaier Mogensen S.A.U.**

C/ Téllez, 24 - Oficina 4A  
28007 Madrid  
Spain  
Phone: +34 91 5776277  
Fax: +34 91 5757495  
info@almo.es  
www.almo.es